



MGM Brakes Service Manual

MODEL TR SERIES
MODEL TR-T SERIES
MODEL TR-TS SERIES
MODEL TR-HD SERIES
MODEL TR-LP3 SERIES

For: Tamper Resistant S-Cam Double Diaphragm Combination Service and Spring Brake Chambers

The MGM Brakes Tamper Resistant spring brake chambers are an important part of your braking system. While they do not require scheduled servicing, it is good preventative maintenance to make the following routine inspections while they are in the shop for regular servicing of other components or at a minimum of every 50,000 miles.

WARNING: YOUR MGM BRAKES TAMPER RESISTANT SPRING BRAKE HAS BEEN FACTORY SEALED FOR YOUR PROTECTION. THERE ARE NO USER-SERVICEABLE PARTS INSIDE THE SPRING BRAKE CHAMBER. IF YOU EXPERIENCE ANY DAMAGE OR FAILURE OF YOUR SPRING BRAKE CHAMBER, REMOVE EITHER THE ENTIRE ACTUATOR AS IN SECTION (3) OF THIS MANUAL, OR THE SINGLE (PIGGYBACK) AS IN SECTION (5) OF THIS MANUAL. SEE SECTION (8) OF THIS MANUAL FOR DISPOSAL INSTRUCTIONS. NEVER ATTEMPT TO DISASSEMBLE THE SPRING BRAKE CHAMBER AS SERIOUS PERSONAL INJURY COULD RESULT FROM ACCIDENTAL SUDDEN RELEASE OF THE HIGH ENERGY SPRING.

SECTION (1): RECOMMENDED INSPECTION POINTS

- (a) The plastic END CAP on all "TR" and "TR-T" models requires no positioning or maintenance, but must be snapped tightly into place. Inspect the cap for damage and replace as necessary. "TR-T" units equipped with a breather tube and the white WEATHER SEAL END CAP must be equipped with a rubber O-ring (Figure 12) to ensure proper sealing of the spring chamber. **Operating units equipped with the BREATHER TUBE without the END CAP or DUST CAP securely in place will void the MGM Brakes warranty without remedy.**
- (b) Visually inspect the exterior surfaces of the unit for signs of damage from outside sources, corrosion and/or rust. If any of these are seen or suspected, cautiously remove the complete combination chamber by following the directions in Section (3) of this manual. Per CVSA out of service criteria, any non-manufactured hole or crack will place the vehicle out of service. (Not Shown)
- (c) Inspect SERVICE BRAKE CLAMP RING to be sure it is securely in place and damage free. If any damage is seen or suspected, cautiously remove the complete piggyback/spring brake chamber by following directions in Section (5) of this manual. **MGM Brakes recommends 30-35 Lbs.-Ft. torque on CLAMP BOLTS.**
- (d) Check to ensure the MOUNTING STUD NUTS are tightened to **133-155 Lbs.-Ft. torque (clockwise)** and washers are in place between the nut and bracket.
- (e) Inspect air lines, hoses and fittings attached to chamber. Replace any damaged or leaking parts. **MGM Brakes recommends the fittings be tightened to 25-30 Lbs.-Ft. torque into the chamber air inlet ports.**

IMPORTANT - Inspect the air ports to determine the model of brake. Round ports denote (2.50 inch) standard stroke model, square ports denote (3.00 inch) long stroke model. This information is important when replacing the service diaphragm and determining the chamber's rated stroke.

- (f) Inspect the PUSH-ROD to be sure it is working free, not bent, not binding and is square to the chamber bottom within $\pm 3^\circ$ in any direction at any point in the stroke of the chamber. If the PUSH-ROD is not square, make corrections by repositioning the chamber on the mounting bracket and/or by shimming the slack adjuster to the right or left on the camshaft as required.
- (g) Inspect the YOKE ASSEMBLY being sure YOKE PIN is installed and locked into place with a COTTER PIN. Replace any damaged, worn or missing parts. **MGM Brakes recommends the YOKE LOCKNUT be tightened to 25-50 Lbs.-Ft. torque.** (Not Shown)
- (h) On units equipped with a DUST BOOT, check the BOOT for damage and replace as necessary. (Not Shown).
- (i) On units equipped with an external BREATHER TUBE (Figure 2) be sure both ends of the connector tube are engaged a minimum of 1/2-inch into each of the flexible elbows. The tube must be glued to both of the elbows with a high quality rubber adhesive or secured with a clamp that may be purchased with the MGM Brakes BREATHER TUBE KIT. These units must be mounted with the BREATHER TUBE in the upper half of the non-pressure chamber facing away from the road surface (Figure 10).

Figure 1

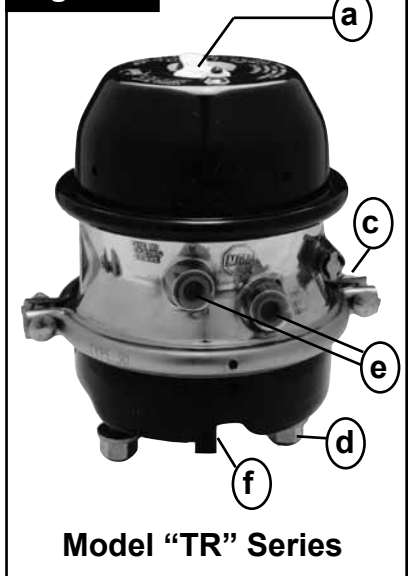
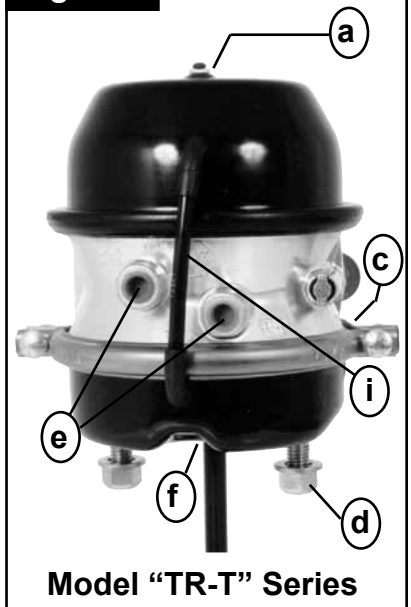

Figure 2



IMPORTANT: Failure to operate any MGM Brakes Model Series “TR-T” or TR-TS” chamber without the EXTERNAL BREATHING TUBE and END CAP with O-ring being present and in good condition will void the MGM Brakes Warranty without remedy.

SECTION (2): MANUAL RELEASE - PARKING BRAKES

- (a) Before releasing the parking brakes, chock wheels of the vehicle to prevent a runaway.
- (b) Remove the plastic end cap from the spring brake chamber (Figure 3).
- (c) Using a 3/4 inch (15/16-inch for TR3036 and TR3636 models) wrench, unscrew the release-nut and remove the nut, flat washer, and release-bolt from their storage pocket on side of chamber for all “TR” series brakes (Figure 4).

IMPORTANT: If these parts are not stored on the chamber, they must be obtained from vehicle tool box or service department, as the piggyback/spring brake cannot be manually released without them.

- (d) Insert the release-bolt into the centerhole of the head (Figure 5) and, being sure that the formed end of the bolt has entered the hole in the piston inside the chamber, continue to insert the bolt until it bottoms out.

IMPORTANT: If you are not absolutely sure of correct bolt-to-piston engagement, repeat this step until you are sure.

- (e) Turn the release-bolt 1/4 turn clockwise and pull the bolt out to lock the formed end into the piston.

IMPORTANT: If the bolt does not lock into the piston in less than 1/2 inch outward movement, repeat steps (d) and (e) until you are sure it does lock.

- (f) Holding the bolt locked into the piston, install the flat washer and the release nut on the end of the release-bolt, and turn down the nut against the flat washer until finger tight (Figure 6).
- (g) Using a 3/4 inch (15/16 inch for TR3036 and TR3636 models) handwrench (**DO NOT USE AN IMPACT WRENCH**) turn the release-nut clockwise until the following length of bolt extends above the nut (Figure 7).

3.25 inch - Type 2430 Chamber
3.25 inch - Type 3030 Chamber

4.00 inch - Type 3036 Chamber
4.00 inch - Type 3636 Chamber



WARNING: DO NOT EXCEED THESE LENGTHS AND DO NOT EXCEED 50 Lbs.-Ft. TORQUE ON RELEASE NUT AT ANY TIME OR DAMAGE MAY OCCUR WHICH COULD PREVENT ANY FUTURE CORRECT MANUAL-RELEASING OF THE PIGGYBACK SPRING BRAKE CHAMBER.

NOTES:

- * For easier manual-releasing, apply 90-125 psi air pressure to inlet port marked “**SPRING BRAKE**” before Step (d) above, but be sure to exhaust all air pressure after Step (g) is completed.
- * To reactivate the piggyback/spring brake from its manually-released position, reverse the order of Steps (a) through (g) above.
- * When re-installing the release-bolt, flat washer and release-nut into the storage pocket, **MGM Brakes recommends 10 Lbs.-Ft. torque on nut against the flat washer** (See Figure 11).

SECTION (3): REMOVAL AND INSTALLATION INSTRUCTIONS FOR “COMBINATION CHAMBERS”

NOTE: Refer to Section (7) before removing air brake chamber to be replaced to ensure that the brake chamber being replaced was properly installed with the correct rod length.

- (a) Determine the manufacturer of the single (piggyback) spring brake or combination chamber to be removed from the vehicle and, following that manufacturer’s instructions exactly, manually release the spring brake completely. (Instructions for all MGM Brakes Model Series “TR”, “TR-T” and single (piggyback) spring brakes having removable bolts are given in Section (2) of this manual. (Service Manuals for all other design series of MGM Brakes piggyback spring brakes are also available upon request to MGM Brakes.)
- (b) Remove the cotter pin from the yoke pin, knock out the yoke pin, and remove both air lines from the assembly.

IMPORTANT: Be sure to mark the air line from the inlet port marked “SPRING BRAKE” for later re-installation reference.

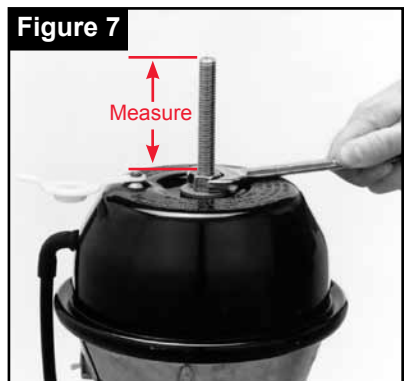
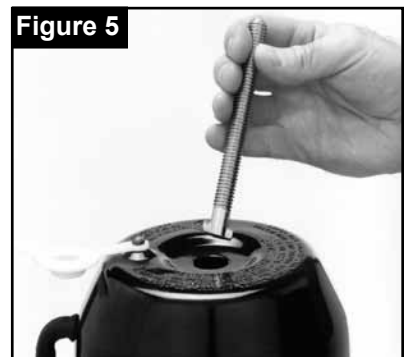
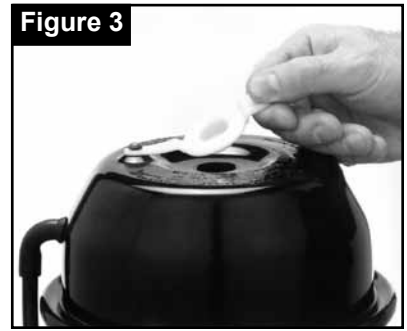
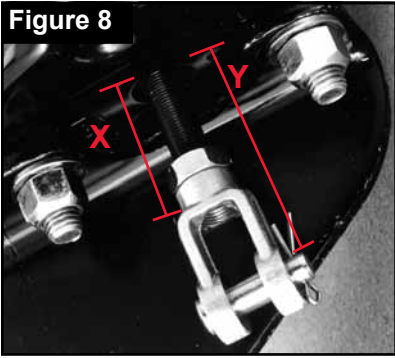

Figure 8



(c) Using a 15/16 inch wrench, unscrew hex nuts on mounting bolts and cautiously remove the old chamber from the mounting bracket.

(d) Follow procedure to cut the service push-rod to proper length (Refer to Section 4).

(e) Remove the hex nut and the flat washers on the mounting bolts of the new chamber, clean the face of the mounting bracket and install the chamber on the bracket with close attention given to positioning the chamber air inlet ports for correct alignment to the vehicle lines. Then install one flat washer and hex nut on each mounting bolt and using a 15/16 inch hand wrench (**DO NOT USE AN IMPACT WRENCH**), tighten nuts to **MGM Brakes recommended 133-155 Lbs.-Ft. torque**.

IMPORTANT: If it is required to reposition the air inlet ports to assure proper mating and alignment with vehicle air lines, refer to Section (5) of this manual and follow Steps (c) through (f) very carefully.

IMPORTANT: When installing any MGM Brakes model with the breather tube it is mandatory to position the non-pressure chamber end of the breather tube in upper half of chamber facing away from the road surface (Figure 10). Failure to comply will void the MGM Brakes Warranty on these models.

Figure 9

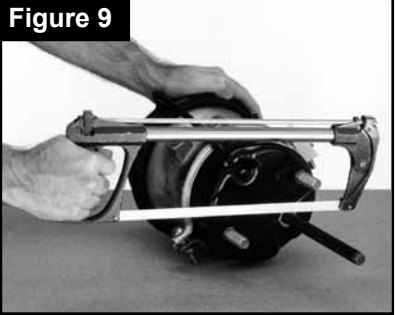

(f) Reconnect yoke to the slack adjuster, being sure that the correct diameter and length of yoke pin is installed into the correct hole in the slack adjuster. Secure the yoke pin with a new cotter pin.

IMPORTANT: When making a reconnection to an automatic slack adjuster follow the vehicle manufacturer's recommendations for installation and set-up.

(g) Inspect the push-rod to be sure that it is working free, not bent, not binding and is square to the chamber bottom within $\pm 3^\circ$ in any direction at any point in the stroke of the chamber. If the push-rod is not square, make corrections by repositioning the chamber on the mounting bracket and/or by shimming the slack adjuster to the right or left on the camshaft as required.

(h) Apply a non-hardening sealing compound to the hose fittings and re-install both of the air lines to the chamber being sure each is mated to the correct air inlet port according to the markings made earlier. **MGM Brakes recommends the fittings be tightened to 25-30 Lbs.-Ft. torque into the chamber air-inlet ports.**

Figure 10

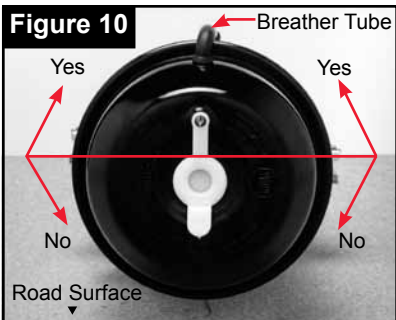

(i) Using the vehicle system air, charge the spring brake with full line pressure (minimum 100 psi). Spray only soapy water or leak detection solution (**NEVER ANY TYPE OF OIL!**) to the air line fittings and inspect for air leaks. If bubbles appear, tighten fittings slightly, but not over 30 Lbs.-Ft. torque.

IMPORTANT: If the service brake clamp ring was loosened to reposition air inlet ports in Step(e) above, apply air to the spring brake and then apply and hold foot brake treadle valve down to charge the service brake chamber. Test for air leaks around the circumference of the service clamp ring using soapy water or leak detection solution. If bubbles appear, firmly tap the circumference of the clamp ring with a hammer and retighten the clamp nuts until leaks cease (Figure 19). MGM Brakes recommends 30-35 Lbs.-Ft. torque on clamp hex nuts. Completely exhaust air from both of the chambers when complete.

(j) With air pressure now exhausted from the service chamber, but still applied on the spring brake, remove release-nut, washer and release-bolt for all "TR" models. Replace these parts in their storage pocket (Figure 4) on chamber (or in vehicle tool box if storage pocket is not present on chamber) and tighten nut against flat washer to 10 Lbs.-Ft. torque.

(k) Replace the END CAP properly (Figure 13). **Operating units equipped with the EXTERNAL BREATHING TUBE without the END CAP and O-RING securely in place will void the MGM Brakes Warranty without remedy.**

Figure 11



IMPORTANT: If chamber is fitted with an external breather tube be sure both ends of the connector tube are engaged a minimum of 1/2 inch into each of the flexible elbows. The tube must be glued to both of the elbows with a high quality rubber adhesive or secured with a clamp that may be purchased with the MGM Brakes Breather Tube Kit. These units must be mounted with the BREATHING TUBE in the upper half of the non-pressure chamber facing away from the road surface (Figure 10).

WARNING: AFTER REPLACEMENT OF ANY BRAKE CHAMBER, THE CHAMBER PUSH-ROD STROKE AND ACTUATING ALIGNMENT MUST BE CHECKED TO ASSURE CORRECT INSTALLATION AND FOUNDATION BRAKE ADJUSTMENT. IT IS VERY IMPORTANT TO RECOGNIZE THAT NO FOUNDATION ADJUSTMENTS CAN BE MADE AT EITHER THE SPRING BRAKE CHAMBER, OR AT THE SERVICE BRAKE CHAMBER, AND THAT ALL "STROKE ADJUSTMENTS" MUST BE MADE AT THE SLACK ADJUSTER ACCORDING TO THE SPECIFIC RECOMMENDATIONS OF THE FOUNDATION BRAKE MANUFACTURER OR THE VEHICLE MANUFACTURER.

SECTION (4): PROCEDURE TO CUT THE SERVICE PUSH-ROD TO PROPER LENGTH



WARNING: DO NOT ATTEMPT TO SERVICE OR DISASSEMBLE THE SPRING CHAMBER OR ANY SPRING BRAKE ACTUATOR. A LARGE SPRING IN THE SPRING CHAMBER HAVING EXTREME FORCE COULD CAUSE SERIOUS BODILY INJURY IF IT WERE SUDDENLY RELEASED DUE TO INADVERTENT REMOVAL OF THIS CLAMP OR TAMPER RESISTANT HEAD.

IMPORTANT: Place blocks under wheels to prevent vehicle runaway before removing air brake actuators.

- (a) REMOVE WORN OR NON-FUNCTIONAL UNIT FROM VEHICLE: Determine manufacturer and model of unit to be replaced. Refer to that manufacturer's service manual for caging and removal instructions.
- (b) Make sure the spring chamber of the removed actuator is fully released (power spring caged) and the service brake push-rod is fully retracted to zero stroke position (i.e., brake fully released).
- (c) Measure and record the "X" and "Y" dimensions (Figure 8).

"X" Dimension - The dimension from bottom of actuator to end of push-rod.

"Y" Dimension - The dimension from bottom of actuator to center line of yoke pin.

NOTE: If for some reason the spring chamber power spring cannot be caged and fully released, then the "X" and "Y" dimensions will need to be measured from another actuator of the exact type from the same vehicle provided it is retracted to its zero stroke position (brake fully released) and was operating correctly.

- (d) Before marking push-rod to be cut on a new unit, be sure the spring chamber and push-rod are fully retracted to the zero position. (This may be done with the manual caging bolt or by applying 90-100 psi air pressure to the spring chamber air inlet port.)
- (e) Take measured "X" dimension from the removed unit and mark push-rod of new unit from the bottom of the actuator.
- (f) Thread yoke jam nut past mark on push-rod. Align bottom edge of nut with mark.
- (g) Use a sharp hack-saw and cut push-rod on the mark (Figure 9).
- (h) After cutting rod, thread jam nut off to clean up the thread.
- (i) Thread jam nut back onto the push-rod a sufficient length to allow assembly of the yoke.
- (j) Thread yoke onto the push-rod. Yoke from removed unit may be reused provided yoke pin hole is not worn. Adjust yoke to the same "Y" dimension as measured from the removed unit.
- (k) Hold yoke to prevent it from turning and tighten locknut against yoke 25-35 Lbs.-Ft. torque.

TO INSTALL NEW UNIT ON VEHICLE: Refer to MGM Brakes Service Manual for the model that is being installed.

SECTION (5): REMOVAL AND INSTALLATION INSTRUCTIONS FOR SINGLE (PIGGYBACK) SPRING BRAKES

The removal and installation of a single spring brake chamber (without removal of the service brake chamber) can be made easier by "locking off" the service chamber piston. To do this apply the service brake by applying the driver's foot brake treadle valve and, while applied, clamp vise-grip pliers on push-rod so that vice-grips abut mounting bracket to prevent rod from retracting when air pressure is released (Figure 15).

- (a) Determine manufacturer of the single spring brake to be removed from the vehicle and, following that manufacturer's instructions exactly, manually release the spring brake completely. (Instructions for all MGM Brakes Model Series "TR", "TR-T" and single spring brakes having removable release bolts are given in Section (2) of this manual. (Service manuals for all other design series of MGM Brakes single spring brakes are also available upon request to MGM Brakes.)
- (b) Remove both air lines from the chamber.

IMPORTANT: Be sure to mark the air line from the inlet port marked "SPRING BRAKE" for later re-installation reference.

Figure 12

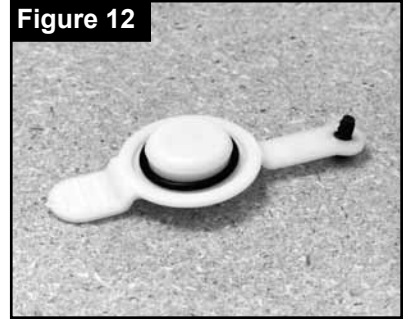

Figure 13



Figure 14

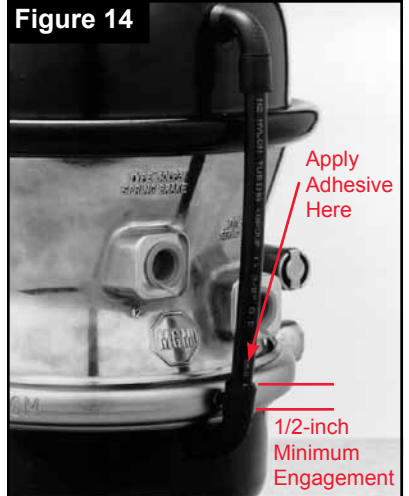
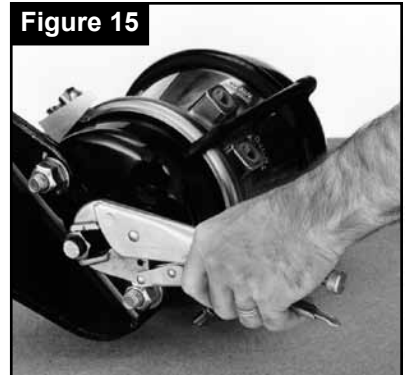
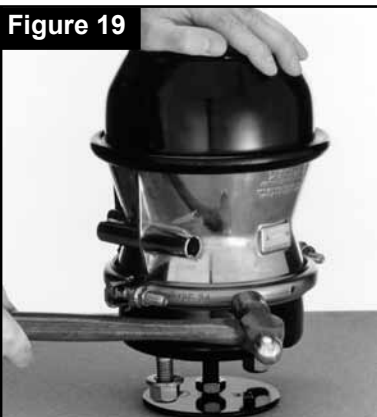
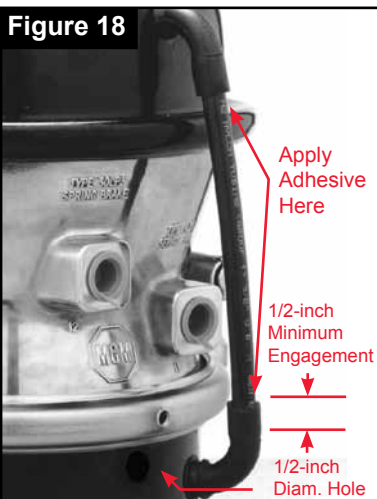

Figure 15





- (c) On all MGM Brakes models fitted with external breather tubes (Figure 2), disconnect the tube and elbow from the service chamber housing (Figure 18).
- (d) Using a 9/16 inch wrench or socket, remove the clamp nuts on the service clamp ring. Then, while holding the single spring brake securely in place, remove the clamp ring to allow removal of the single brake from the service chamber (Figure 16).

IMPORTANT: At this time take the opportunity to inspect all parts in the service chamber (especially the diaphragm) and replace the return spring, and any other parts which may be damaged or worn. Use only genuine MGM Brakes Engineered replacement parts!

- (e) Make sure the new single (piggyback) spring brake is fully released as outlined in Section (2) of this manual. Position the diaphragm in the bottom recess of the chamber (Figure 17) and, with very close attention taken to assure all mating parts are aligned straight and the air lines are positioned to mate with the vehicle air supply lines, replace the service clamp ring (Figure 16).
- (f) Re-install the clamp bolts and nuts. **Alternately tighten each nut in 5-10 Lbs.Ft. torque increments** while constantly rechecking mating parts alignment. (If re-alignment is required, loosen clamp nuts and repeat Step (e) above). Firmly tap around circumference of the clamp ring with a hammer to assure the full seating of the clamp (Figure 19) and **tighten the nuts to 30-35 Lbs.-Ft. torque.**
- (g) Apply a non-hardening sealing compound to the hose fittings and re-install both of the air lines to the chamber, being sure each is mated to the correct air inlet port according to the markings made earlier. **MGM Brakes recommends the fittings be tightened to 25-30 Lbs.-Ft. torque into the chamber air inlet ports.**
- (h) Using the vehicle system air, charge the spring brake with full line pressure (minimum 100 psi). Spray only soapy water or leak detection solution (NEVER ANY TYPE OF OIL!) to the air line fittings and inspect for air leaks. **If bubbles appear, tighten fittings slightly, but not over 30 Lbs.-Ft. torque.**
- (i) With the spring brake still fully charged with full line pressure, apply and hold foot brake treadle valve down to charge the service brake chamber.

IMPORTANT: At this time, remove the vise-grip pliers (Figure 15) from the service push-rod so that the piston can return to a normal position in the chamber. Now test for air leaks around the circumference of the service clamp ring by spraying with soapy water or leak detection solution. If bubbles appear, firmly tap the circumference of the clamp ring with a hammer and retighten the clamp nuts until leaks cease (Figure 19). MGM Brakes recommends 30-35 Lbs.-Ft. torque on the clamp hex nuts.

- (j) On all MGM Brakes models fitted with an EXTERNAL BREATHING TUBE, wipe the open end of the connector tube clean to be sure that no oil is present, apply a high quality rubber cement to the tube and re-insert tube into flexible elbow a minimum 1/2 inch engagement (Figure 14). If the old single unit was not equipped with an EXTERNAL BREATHING TUBE, drill a 1/2 inch diameter hole 1 inch from the top of the non-pressure chamber (Figure 18), at a point closest to the centerline between the air ports, but in the upper half of the chamber facing away from the road surface (Figure 10). Remove any burrs around the hole, install a new rubber elbow in the non-pressure chamber, wipe the open end of connector tube clean to be sure no oil is present. Apply a high quality rubber cement to the tube and insert the tube into the flexible elbow with a minimum 1/2 inch engagement (Figure 18).

IMPORTANT: These units must be mounted with the BREATHING TUBE in the upper half of the non-pressure chamber facing away from the road surface (Figure 10) and the tube glued or clamped securely into the rubber elbows (Figure 14). Failure to comply with these installation instructions will void the MGM Brakes Warranty without remedy.

- (k) With air pressure exhausted from the service chamber, but with line pressure still on the spring brake, remove the release nut, washer and bolt for all "TR" models. Replace these parts in their storage pocket (Figure 4) on the chamber (or in the vehicle tool box if a storage pocket is not on the chamber) and **tighten the nut against the flat washer to 10 Lbs.-Ft. torque.**
- (l) **Replace the end cap properly (Figure 13). Operating these units without the END CAP securely in place will void the MGM Brakes Warranty without remedy.**

SECTION (6): REMOVAL AND INSTALLATION INSTRUCTIONS FOR "SERVICE BRAKE DIAPHRAGM"

- (e) Follow all instructions given in Section (5) of this manual and install the new diaphragm in Step (5-e). Use only genuine MGM Brakes Engineered replacement diaphragms!



WARNING: WHEN SERVICING A 3-INCH "LONG STROKE" MODEL BRAKE, BE SURE TO REPLACE WITH THE CORRECT DIAPHRAGM. INSTALLATION OF A STANDARD (2.50 INCH) STROKE DIAPHRAGM IN A 3-INCH "LONG STROKE" CHAMBER COULD RESULT IN CATASTROPHIC FAILURE OF THE UNIT.

IMPORTANT: It may not be necessary to disconnect the air lines from the spring brake during this procedure as long as correct and straight parts alignment can be obtained during the re-assembly operations.

SECTION (7): CAM BRAKE ADJUSTMENT - ALL MODELS SPRING BRAKE AND SERVICE BRAKE ACTUATORS

NOTE: The last half of an air chamber stroke is less efficient than the first half. Therefore, the following adjustments are recommended for maximum efficiency when using manually adjusted slack adjusters.

BRAKES "OFF" - NOT APPLIED

Angle must always be greater than 90° due to various slack adjuster lengths and installation setups. (Refer to axle or OEM manufacturer's manual for recommended angle).

Stroke should be as short as possible with no lining to drum contact.

PROPERLY - ADJUSTED BRAKES "ON" - APPLIED

To check brake adjustment, apply 90 to 100 psi air pressure to the service chamber. Consult the vehicle manufacturer for the correct angle between the slack adjuster arm and push-rod and/or the push-rod length. This is necessary since different dimensions are required for automatic or manual slacks, various slack lengths and different slack adjuster manufacturers.

IMPROPERLY ADJUSTED BRAKES "ON" - APPLIED
(Maximum recommended readjustment stroke has been exceeded)

MGM Brakes "Stroke Alert"
(Excessive Stroke Warning)

See chart on right for recommended readjustment stroke

Type	Effective Area (Sq. in.)	Approximate Diaphragm O.D.		Rated Stroke of Chamber		Maximum Stroke with Brakes Adjusted	"B" MV/MA Recommended Re-adjustment Stroke	
		Inches	MM	Inches	MM		Inches	MM
9	9	5.00	125	1.75	45	SHOULD BE AS SHORT AS POSSIBLE WITHOUT LINING TO DRUM CONTACT	1.35	35
12	12	5.50	140	1.75	45		1.35	35
16	16	6.00	150	2.25	57		1.75	45
16L	16	6.00	150	2.50	64		2.00	51
20	20	6.50	165	2.25	57		1.75	45
20L	20	6.50	165	2.50	64		2.00	51
24	24	7.00	175	2.25	57		1.75	45
24L	24	7.00	175	2.50	64		2.00	51
24LP3	24	7.00	175	3.00	76		2.50	64
30	30	8.00	200	2.50	64		2.00	51
30LP3	30	8.00	200	3.00	76		2.50	64
36	36	9.00	230	3.00	76		2.25	57

SOURCE: MVMA (Motor Vehicle Manufacturers Association)

Note: The push-rod must remain perpendicular to the bottom surface of the non-pressure chamber (NPC) within ±3° zero to full stroke.

SECTION (8): RECOMMENDED SPRING BRAKE ACTUATOR DISARMING PROCEDURE



WARNING: THIS PROCEDURE MUST BE STRICTLY ADHERED TO. NEVER ATTEMPT TO REMOVE THE SPRING CHAMBER CLAMP RING FROM A DOUBLE DIAPHRAGM ACTUATOR OR THE SPRING CHAMBER RETAINING RING FROM A PISTON ACTUATOR. BOTH ACTUATORS EMPLOY A HIGH ENERGY POWER SPRING THAT COULD CAUSE SERIOUS BODILY INJURY IF THE SPRING WERE SUDDENLY RELEASED DUE TO IMPROPER DISASSEMBLY.

All retired spring brake actuators must be safely disarmed before they are disposed of to prevent serious personal injury from accidental sudden release of the high energy spring (as much as 2700 Lbs. of force) in the parking chamber. To disarm the unit, remove it from the vehicle following the instructions in Section (3) for combination chambers, or Section (5) for single/piggyback chambers. Be sure to release the brake per Section (2) of this manual. Never attempt to remove the head which contains the power spring. Observe all safety precautions. Place the unit in a steel *container and use an acetylene torch to cut a hole through the head housing the power spring. Cut completely through at least two spring coils. The steel container must have openings to expose the head where it is to be cut with the acetylene torch and it must be strong enough to prevent parts from hurtling out should the unit suddenly separate before it is safely disarmed. It is the users responsibility to ensure the steel container is safe.

*Information concerning a suitable container is available through your MGM Brakes Representative.



A Division of Indian Head Industries, Inc.
8530 Cliff Cameron Drive • Charlotte, NC 28269-9786 • (704) 547-7411 • (800) 527-1534 • FAX: (704) 547-9367
e-mail: mail@mgmbrakes.com • www.MGMBrakes.com