



*50 Years of Leadership*



## Field Replacement of Chambers Equipped with “Welded” Yokes

*By* MGM Brakes

8530 Cliff Cameron Drive  
Charlotte, NC 28269-9786  
Phone: (704) 547-7411  
Fax: (704) 547-9367  
Website: [www.MGMBrakes.com](http://www.MGMBrakes.com)  
Email: [mail@mgmbrakes.com](mailto:mail@mgmbrakes.com)

©2006 MGM Brakes. All Rights Reserved. Printed in the U.S.A.



## Field Replacement of Chambers Equipped with "Welded" Yokes

Everyday, more and more vehicles are being manufactured with 3-inch "long stroke" spring brakes and service chambers with the yoke "welded" to the service push-rod.

Because the "welded" yoke is permanently attached to the push-rod, it is virtually impossible to remove and re-use it. Therefore, unless the non-pressure housing (mounting base), push-rod, and/or yoke have been damaged, or are severely worn, MGM Brakes recommends replacement of the single/piggyback unit only.

However, if replacement of the combination/tandem unit is required, it is recommended that a unit equipped with a "welded" yoke be used.

Units manufactured with a "welded" yoke have preset "Y" dimension, measured from the bottom of the NPC to the center-line of the yoke pin, of 2.25 - inches. Because the "Y" dimension is relatively short, the corresponding "X" dimension, measured from the bottom of the NPC to the end of the rod, will also be short, at approximately  $\frac{3}{4}$  of an inch.

Consequently, if a replacement unit with a "universal" all-threaded cut-to-fit push-rod is used, the "stack-up" of the yoke and jam nut will exceed the "X" dimension by approximately  $\frac{1}{8}$ th of an inch.

In some cases, this will prevent the unit from achieving zero-stroke, or, if the push-rod opening in the NPC is large enough, the jam nut will protrude into the NPC and may damage the protective stone shield.

Spring brakes and service chambers must fully retract to zero-stroke in order to completely release the foundation brakes so the lining no longer contacts the drum, and allow the automatic slack adjusters to properly operate and adjust the stroke.

Therefore, do not use a replacement unit with a universal all-threaded cut-to-fit push-rod to replace a unit with a "welded" yoke.

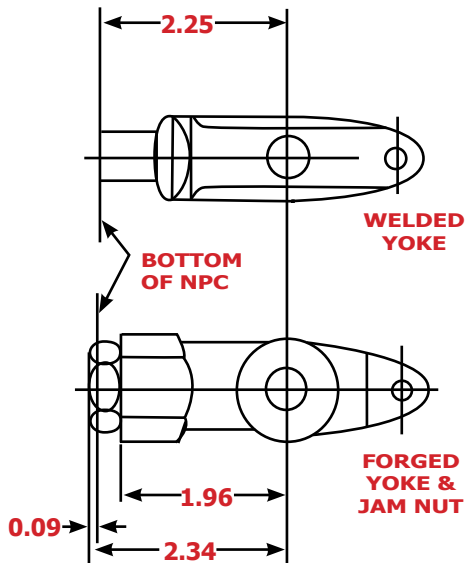

Information taken from technical bulletin 003-002

**NOTE: Be sure to always replace like for like. Do not mix 2.5-inch "standard stroke" chambers with 3-inch "long stroke" chambers across the axle. Reference MGM Technical Bulletin 03-002, issued 4/2/2003**