

Remote Mount Cylinders

Pull Type

When Dependability Matters...



Count on MGM Remote Cylinders



Introduced 50-years ago as the world's first spring-actuated parking and emergency brake actuators for commercial vehicles, the MGM R4 and R5 Remote-Mount Cylinders have registered millions of miles and millions of hours of service in many diverse and harsh applications, such as: dump truck/trailer end-gate actuators, emergency brake actuators on massive logging and commercial fishing winches, and numerous other special applications where there is a need for a dependable, rugged, light-weight pull-type actuator.

Built durable for tough jobs!



MGM Brakes

A Division of Indian Head Industries, Inc.

Form 5088

Pull Type Actuators Built Tough Since 1956!

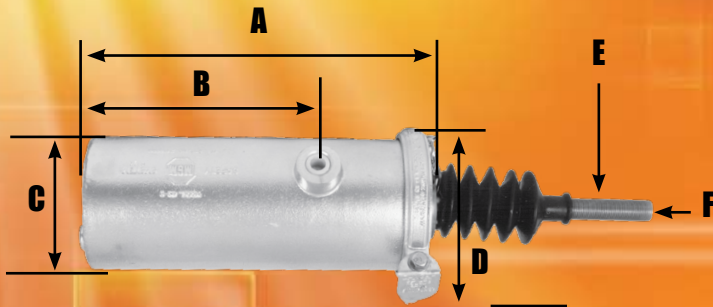

R4 MODEL

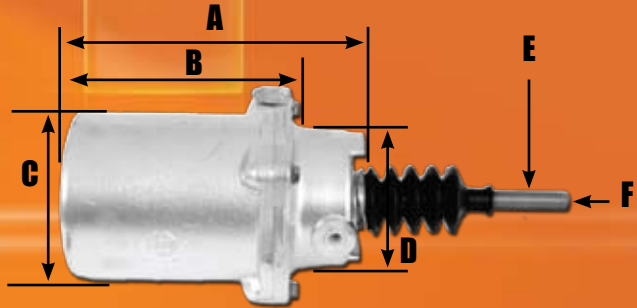

R5A MODEL

First introduced in 1956 as the world's first spring-actuated parking and emergency brake actuators for commercial vehicles. These "pull-to-activate" cylinders were designed for axle-mount using various weld-on and bolt-on mounting brackets and linkage arms.

Model	R4	R5	R5HD
Stroke	4.5"	4.4"	4.41"
Weight (lbs.)	13.25	16.3	17.6
Hold off PSI	80	56	80
A	11.12	10.5	10.5
B	7.5	9.38	9.38
C	4.38	6.12	6.12
D	5.69	5.12	5.12
E EXTERNAL THREAD	3/4 NF	3/4 NF	3/4 NF
F INTERNAL THREAD	1/2 UNF 2B 3" DEEP	1/2 UNF 2B 3" DEEP	1/2 UNF 2B 3" DEEP

NOTE: All measurements are in inches.

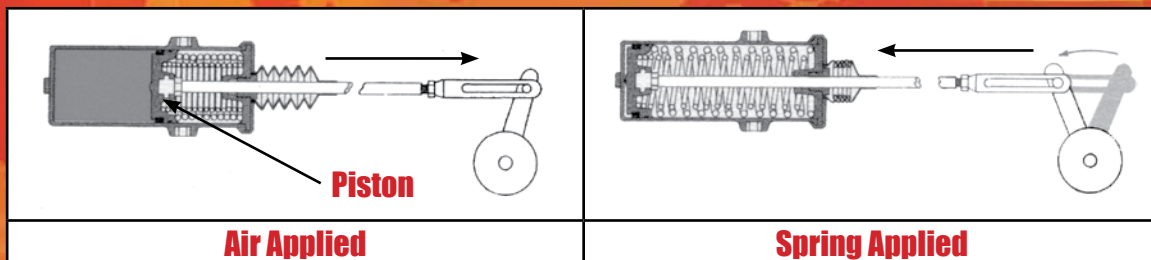

Product information and specifications
subject to change without notice.

www.MGMBrakes.com

Form 5088 ©2008 MGM Brakes. All Rights Reserved Printed in U.S.A.